

TOUCH SIDE VIEW

Pin#	Assignment
1	UR
2	LR
3	S
4	UL
5	LL

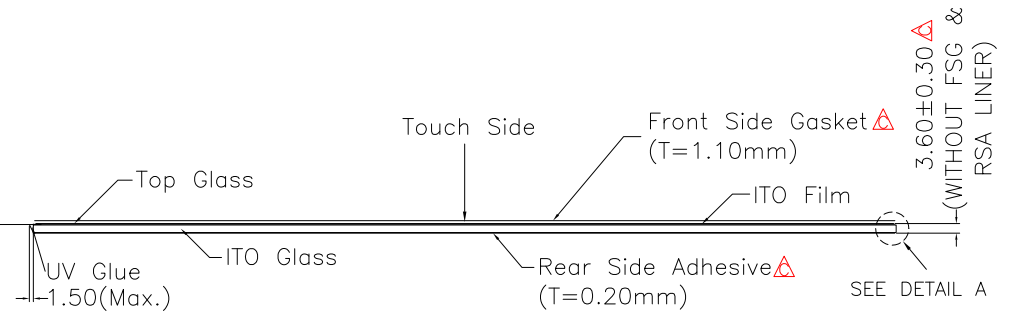
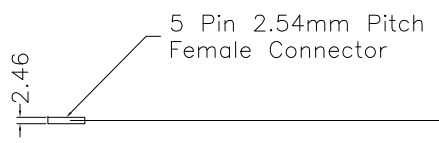
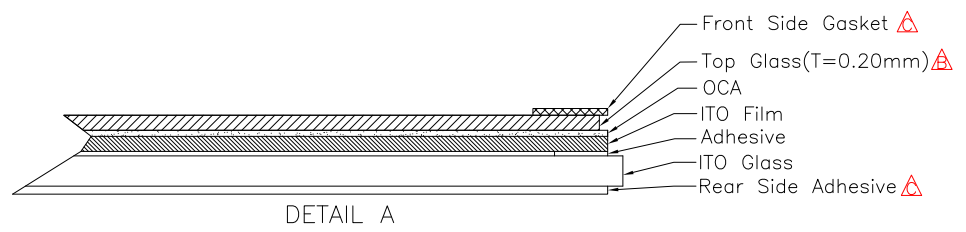
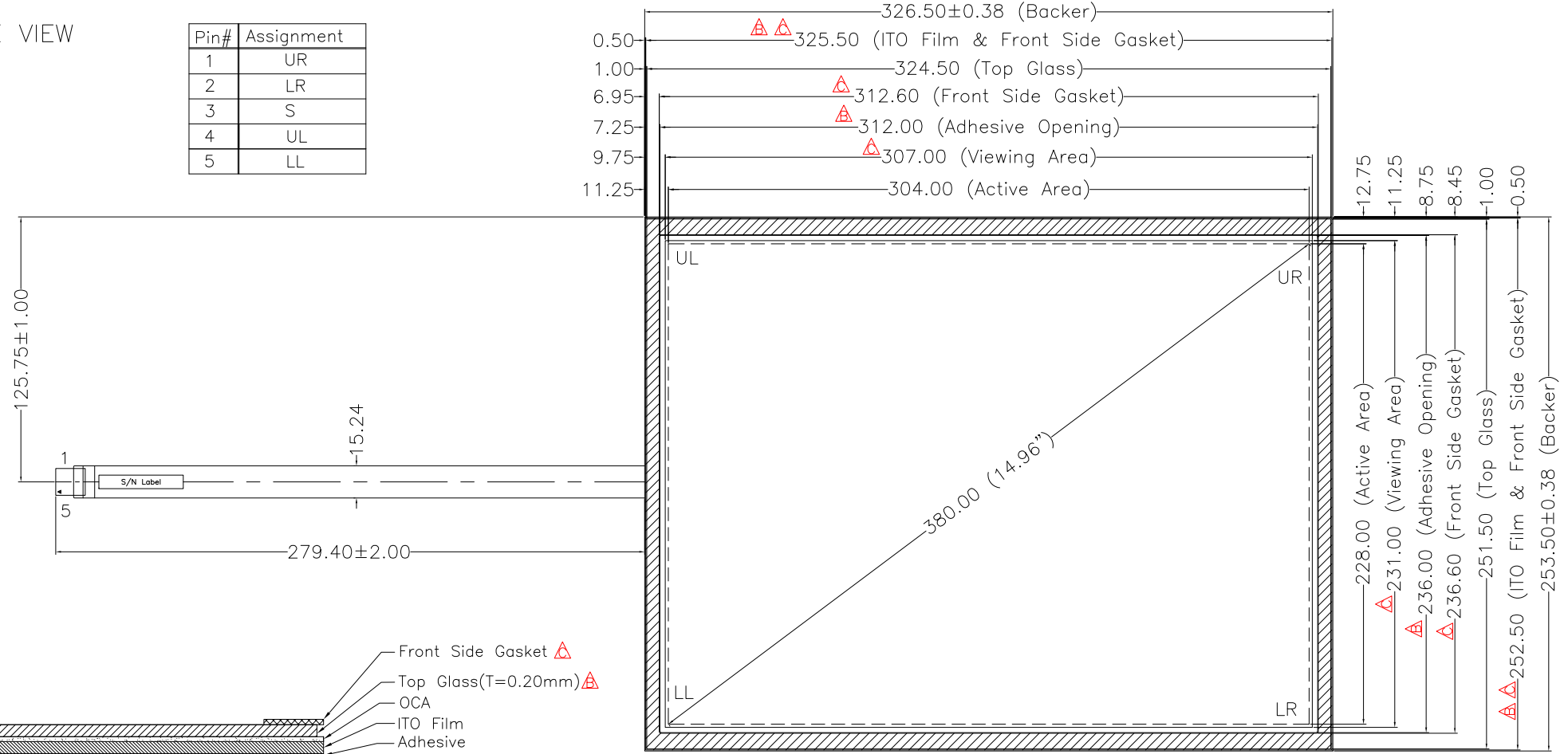

- NOTES:
1. ITO GLASS THICKNESS : 2.80mm
 2. OVERALL THICKNESS : 3.60±0.30mm (WITHOUT FSG & RSA LINER)
 3. CONNECTOR AND PINOUT AS INDICATED
 4. TOP GLASS SURFACE TYPE : CLEAR
 5. TAIL TYPE : GOLD PLATED FPC WITH AMP-COMPATIBLE TIN PLATED CONTACTS
 6. FRONT SIDE GASKET(FSG) : AMT GASKET & ADHESIVE SAMPLES BOOK(C1+A2)
 7. OTHER SPEC : SEE APPROVAL SHEET
 8. PLEASE REFER TO GFG INTEGRATION GUIDE BEFORE ASSEMBLY FOR SPECIAL ATTENTION

O1C	Oct.16, 2015	MODIFY PROCESS, REMOVE PET, ADD FSG & RSA & VIEWING AREA DIMENSIONS	Grace
O0B	APR.20, 2011	MODIFY PET & ADHESIVE OPENING DIMENSIONS MODIFY 0.2mm TOP GLASS	Grace
O0A	JUN.29, 2010	MODIFY PET DIMENSIONS	Alex
NO.	DATE	DESCRIPTION	CHK
REVISION			
CHIEF OF DESIGN		APPROVED	Grace
DRAWN BY	Arthur	DATE	Oct.16, 2015
SHEET 1 OF 2			

Apex Material Technology Corp.	
TOLERANCES UNLESS SPECIFIED	DWG NO :
.X	± 0.50
.XX	± 0.50
.XXX	± 0.30
ANGULAR	.
16004-01-3-01	
SCALE: 1:1 UNIT: mm	



REAR SIDE VIEW

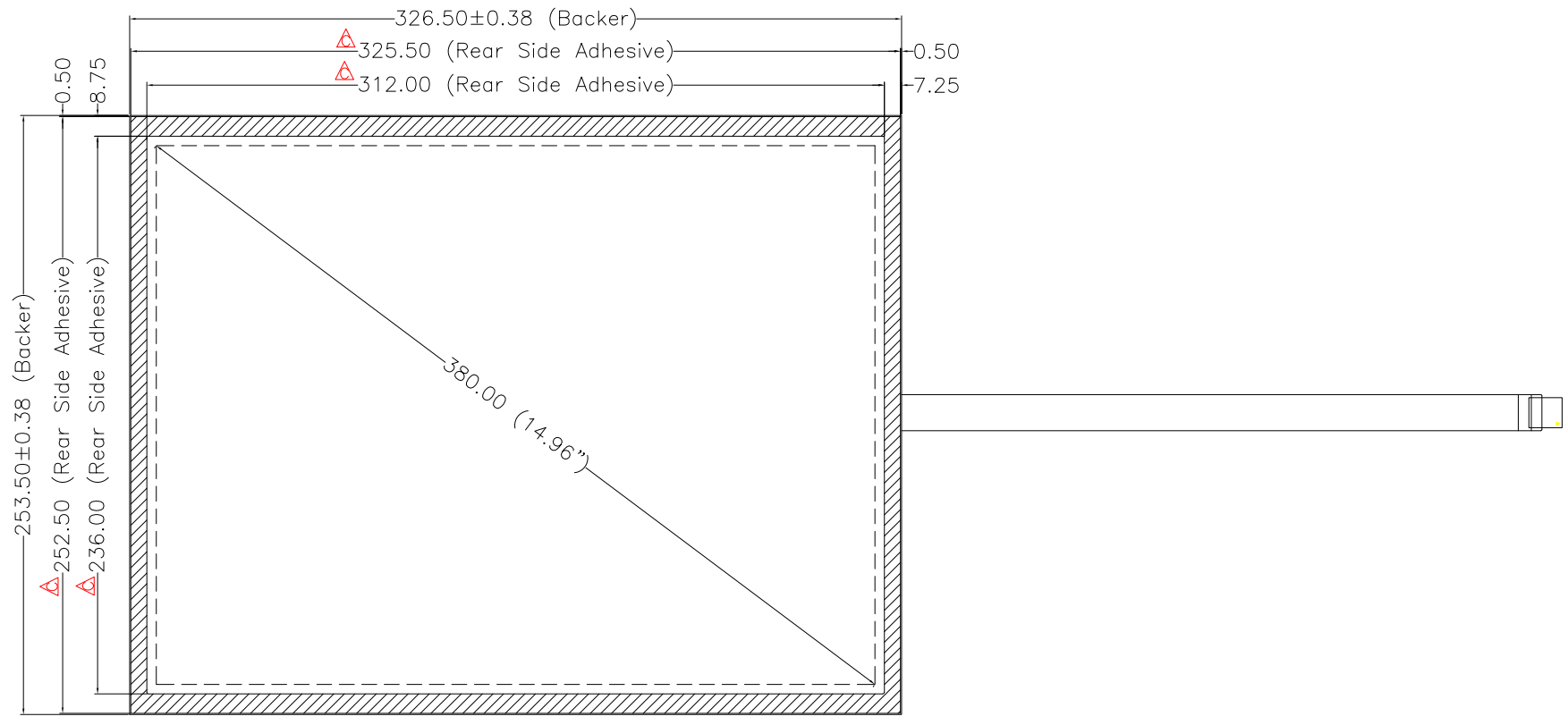

NOTES:
 △1. REAR SIDE ADHESIVE(RSA) : AMT GASKET & ADHESIVE SAMPLES BOOK(A6)



O1C	Oct.16, 2015	MODIFY PROCESS, REMOVE PET, ADD FSG & RSA & VIEWING AREA DIMENSIONS	Grace
O0B	APR.20, 2011	MODIFY PET & ADHESIVE OPENING DIMENSIONS MODIFY 0.2mm TOP GLASS	Grace
O0A	JUN.29, 2010	MODIFY PET DIMENSIONS	Alex
NO.	DATE	DESCRIPTION	CHK
REVISION			
CHIEF OF DESIGN		APPROVED	Grace
DRAWN BY	Arthur	DATE	Oct.16, 2015
SHEET 2 OF 2			
TOLERANCES UNLESS SPECIFIED		DWG NO :	
.X	± 0.50	16004-01-3-01	
.XX	± 0.50		
.XXX	± 0.30		
ANGULAR	.	SCALE: 1:1 UNIT: mm	

Apex Material Technology Corp.